



CYBER RANGES



LEARN



TEAM UP



COMPETE

www.cyberranges.com

About Silensec

- ISO27001 certified by the British Standardization Institute (BSI) since 2014
- Re-certification audit in July 2020 to include CYBER RANGES product and services.

bsi.



Certificate of Registration

INFORMATION SECURITY MANAGEMENT SYSTEM - ISO/IEC 27001:2013

This is to certify that:
G & N Silensec LTD
G & N Court
41 Pafou Street
Limassol

The Information Security Management System applies to the provision of the Silensec CYBER RANGES products and services, information security training and consultancy services and 24/7 SOC and managed security services including the support functions of IT, Sales, Finance and Administration in accordance with the Statement of applicability, SIL REC-008_v1.6 Date 25/06/2020.

Holds Certificate No:
and operates an Inform
27001:2013 for the foli

The Information Security Management System applies to the provision of the Silensec CYBER RANGES products and services, information security training and consultancy services and 24/7 SOC and managed security services including the support functions of IT, Sales, Finance and Administration in accordance with the Statement of applicability, SIL REC-008_v1.6 Date 25/06/2020.

For and on behalf of BSI:

Andrew Launn, EMEA Systems Certification Director

Original Registration Date: 2020-07-13
Latest Revision Date: 2020-07-27

Effective Date: 2020-07-13
Expiry Date: 2023-07-04

Page: 1 of 2



...making excellence a habit.™



Limassol (CY) - HQ
Sheffield (UK)
Nairobi (KE)

Services

- Security Audit and Compliance
- Security Systems Integration
- 24x7 SOC
- Managed Security
- Security Training

About us

- Est. in May 2006 in Sheffield
- Privately owned
- 55 people ... and growing

Leadership in Cyber Range Domain



Leading the WG 5 of European Cyber Security Organisation (ECSO), and also specifically on Cyber Ranges SWG 5.1 and Education & Training SWG 5.2

Editor and main author of the **ECSO Paper on Cyber Ranges** (rel. on 30-Mar-2020)



Official platform being used by the UN for the organization of regional and national cyber drills since 2017 – powered up the **ITU 2020 Global Cyber Drill** with 213 participants (58 countries)



Awarded several EU research grants related to cyber ranges and their application



CYBER RANGES

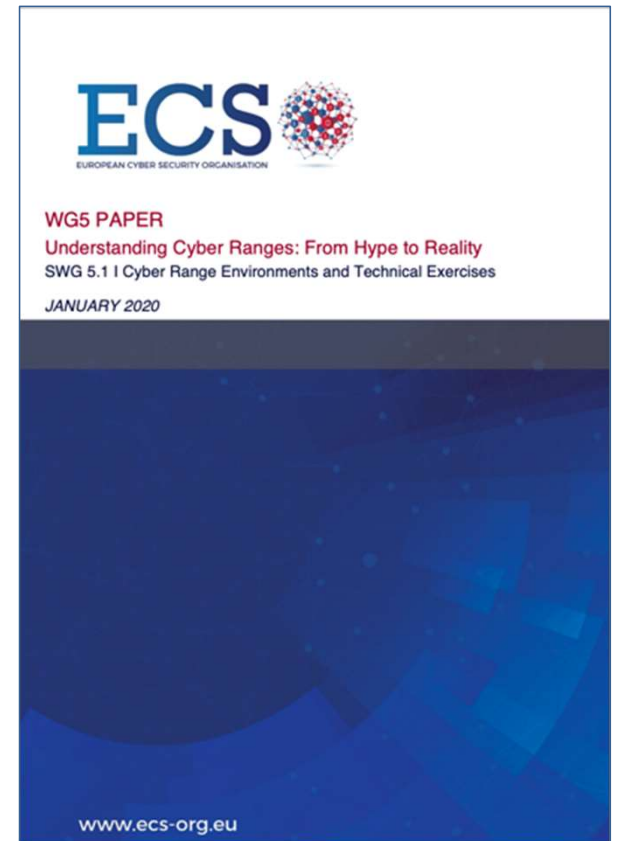

Next-generation Architecture

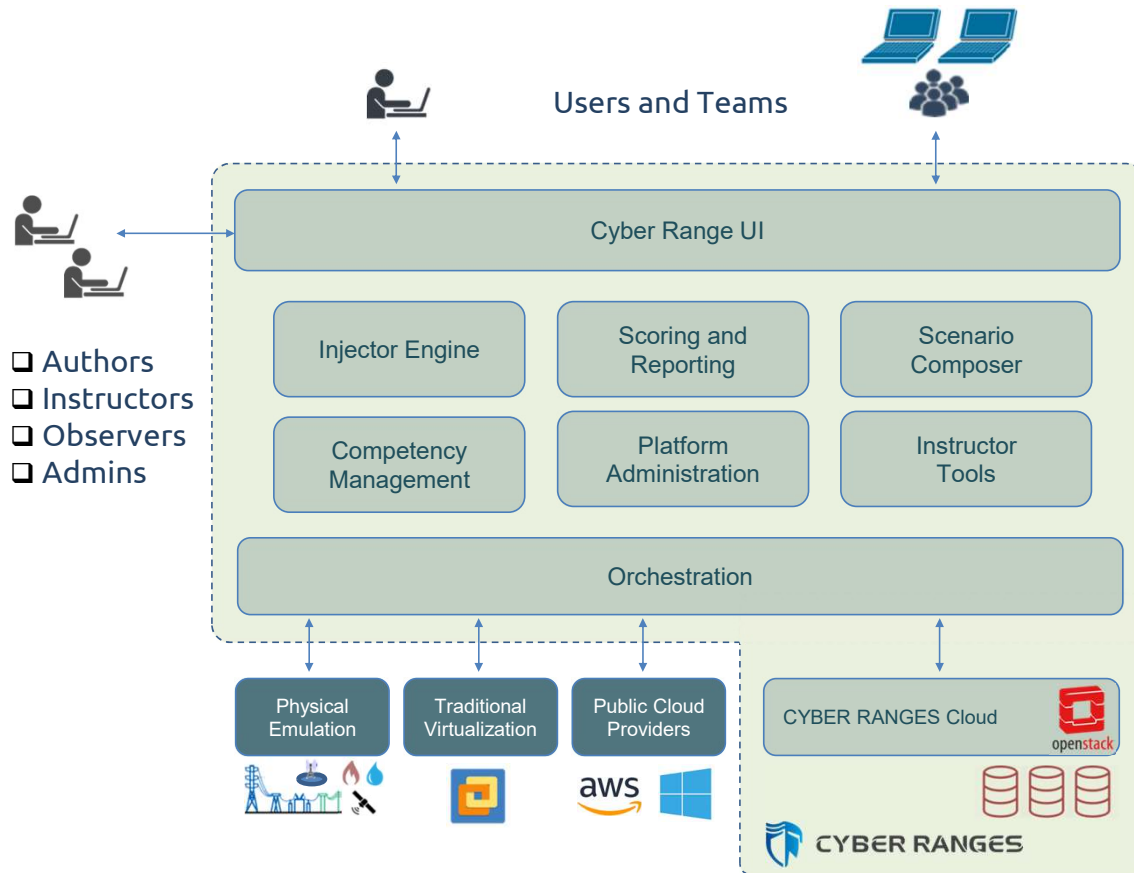

NEXT-GENERATION CYBER RANGE

- Full Stack Technology on bare-metal servers
- Fully owned IPR
- Flexible deployment options
- Powerful orchestration
- Scenario composition
- Library of Scenarios, attacks and assessments
- Library of infrastructure assets and integration of 3rd party technologies
- Attack and user traffic simulation
- Multi-user events automation
- Multiple user roles

Deployment Options



Cyber
Range
as a
Service



Hosted



On Premise



Portable

CYBER SPACE, ENGAGED.



CYBER RANGES

CYBER RANGES PORTABLE

- Pelican case, ruggedized carry-on
- Five-minute deployment
- 3 x Custom Laptops with CYBER RANGES Installed
- 1 x Wireless Access Point with Internet access module
- 1 x Network Switch and cabling
- Injector Engine for user traffic and attacks simulation
- Library of pre-loaded CYBER RANGES Scenarios





CYBER RANGES

Functionalities at Glance



Library of Scenarios

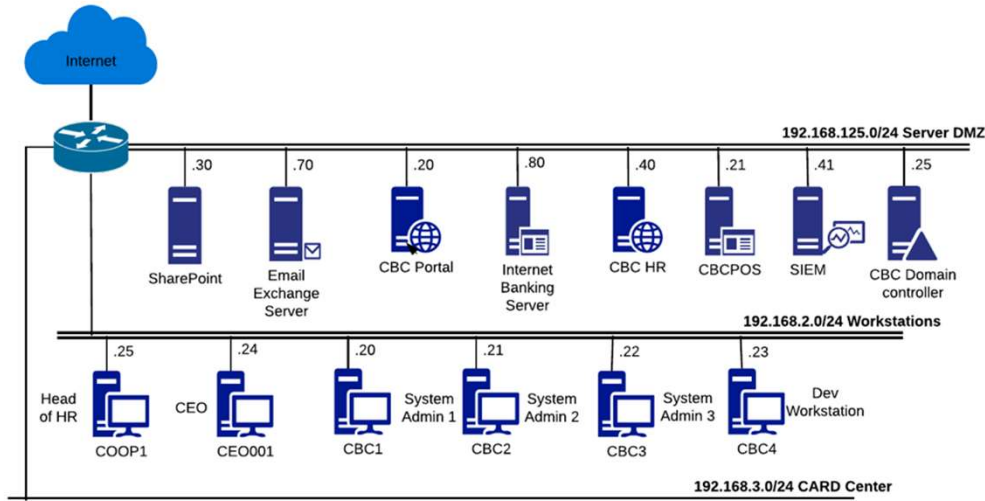

BRANCH		ACCOUNT TYPES		EMPLOYEES		LOAN TYPE	
TRANSACTION ID	TRANSACTION DATE	PAYMENT DATE	PAYEE ID	RECEIVER ID	DEBIT ACCOUNT	AMOUNT	PAYMENT STATUS
2829190	2020-01-11	2020-01-11 04:30:20	23918910	39202819	4548928291	10000.00	active
3829191	2020-01-11	2020-01-11 04:30:20	38291828	2829192	55333000847	2500.00	active



- Learning Paths
 - SOC Analyst
 - System administration
 - Penetration testing
 - Malware analysis
 - ... and many more

- Corporate Scenarios
 - Red Team
 - Red vs Blue Team
 - Incident Response

- MITRE ATT&CK Scenarios
 - Multiple attack techniques
 - Multiple CVEs

Scenario Composition

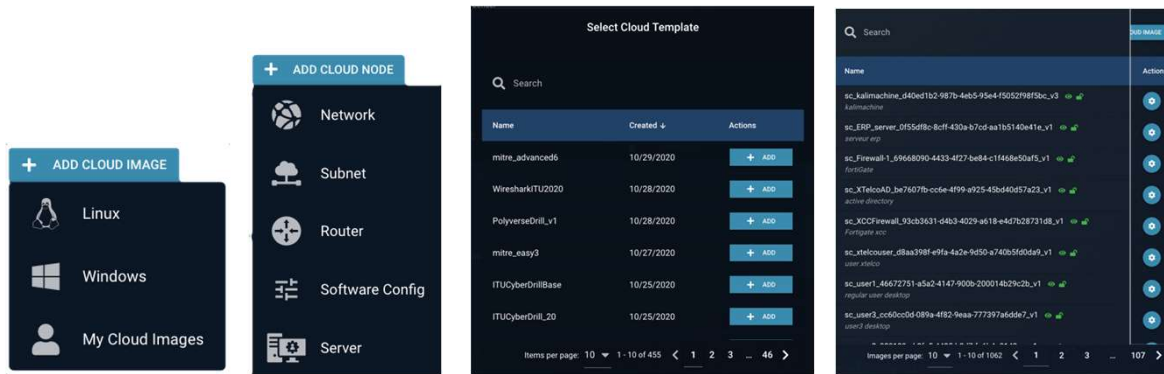

Build multi-segment Networks From Scratch

Reusable Library of VMs and Simulation Environments

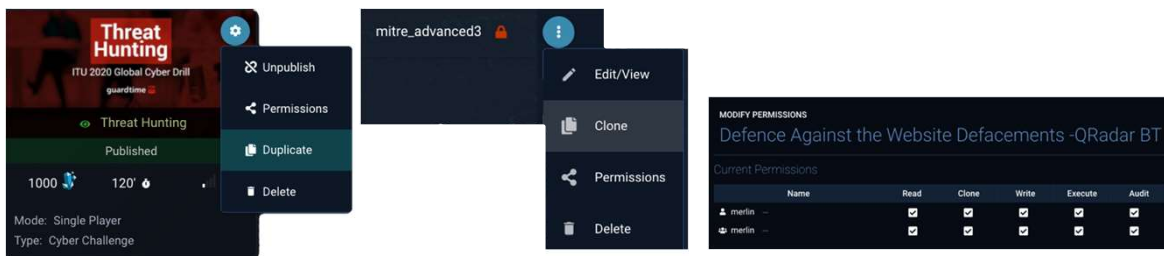

One-Click Cloning and Repurposing of Any Scenario

Full ACL Support for Authors Collaboration



- Library of Content
 - Virtual Machines
 - Simulation Environments
 - Assessments
- Scenario Repurposing
 - Cloning of Scenarios
 - Cloning of simulation environments
- Full ACL Support
 - Scenarios
 - Simulation Infrastructures

Usability

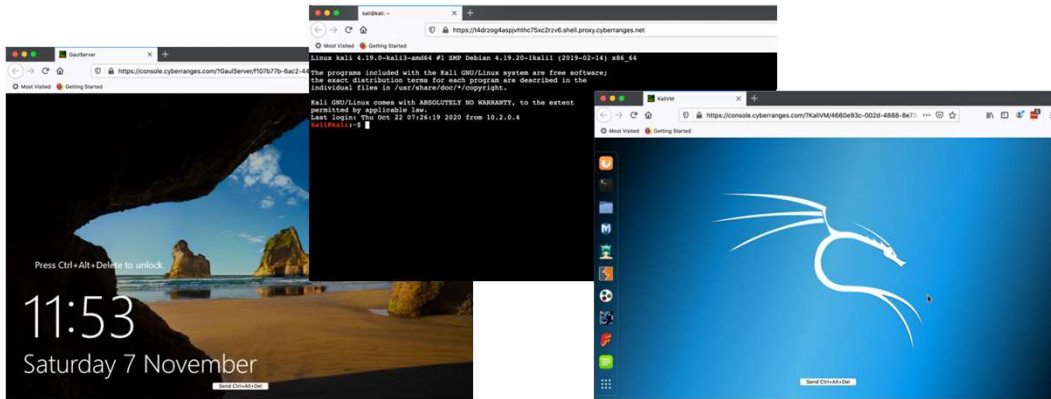

In-Browser Access to the Simulation Environment

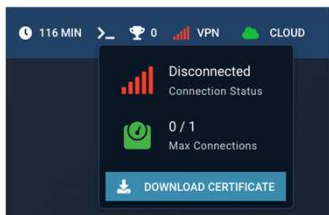

Access via VPN for
for
BYOD Engagements



Individual access
to the VMs



- Per-VM Access Modes

- VPN
- Web Shell
- Remote Console
- Web Proxy

- Individual Access to VMs

- Restart
- Reset



User Traffic & Attack Simulation

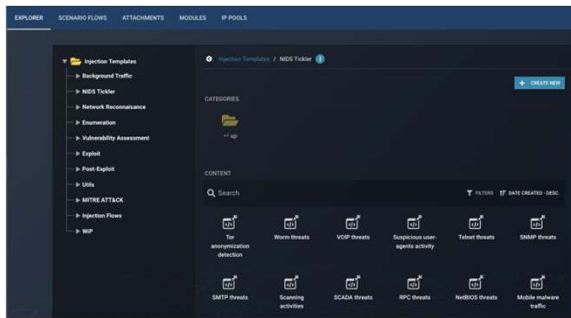

Configurable Attack Library

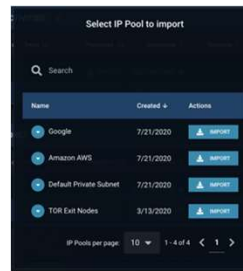
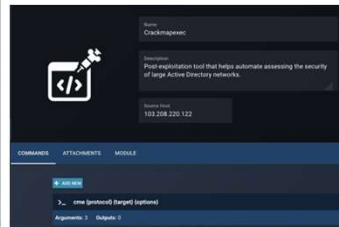

Configurable IP Address Pools

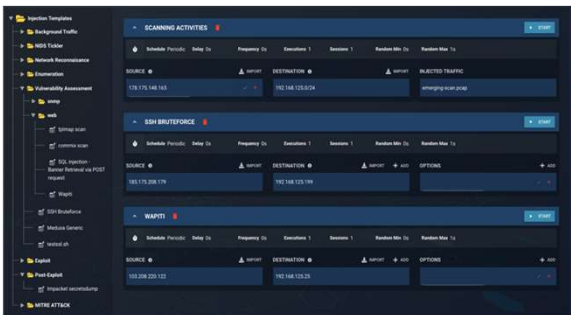

Configurable Live Injections

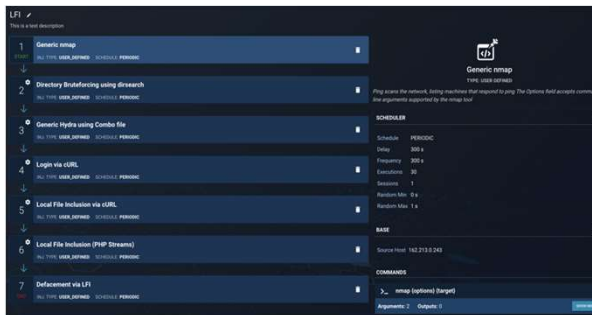

Per-Scenario Attack Flows



CYBER RANGES

- Agent-based attack and user traffic simulation engine
- Background Traffic Simulation
- Stateful attack injection
- Simulation of false-positive attacks
- Red Team Automation
- Configurable Attack Library
- Live injections during scenarios
- Configurable IP Address Pools
- Automatic orchestration of attacks

Orchestration

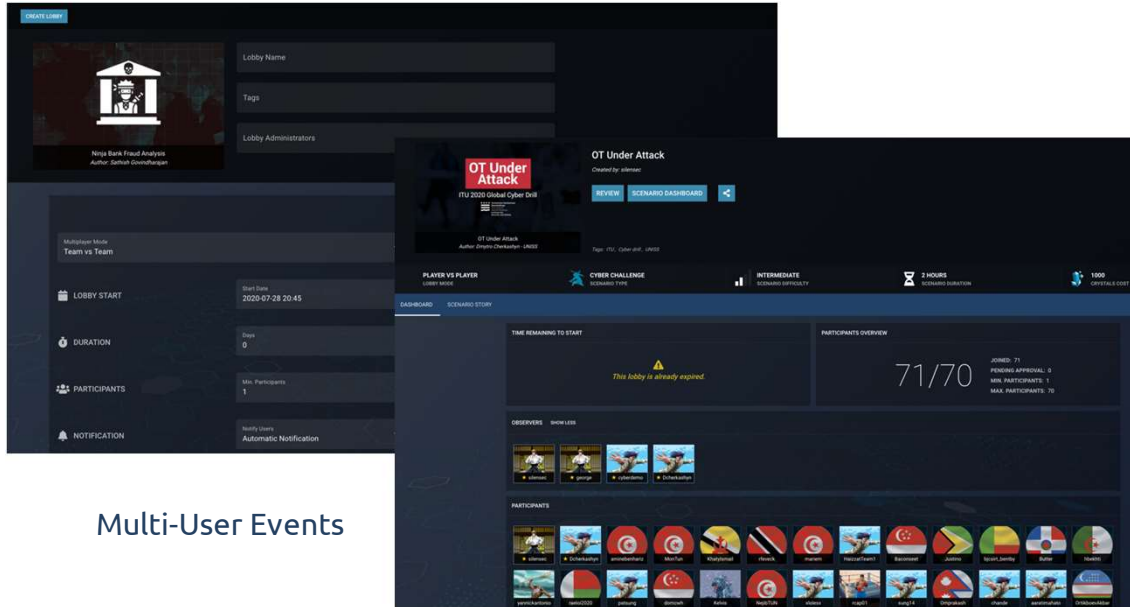

Multi-User Events

Name	Scenario	Players	Host	Duration	Starting on
Cyprus Cybersecurity Challenge 2020 - QA	Cyprus Cybersecurity Challenge 2020	0	tkchoqe	20160 min	22/07/2020
Cyprus Cybersecurity Challenge 2020 - QA	Cyprus Cybersecurity Challenge 2020	1	tkchoqe	20160 min	21/07/2020
Bank Scenario #2 QA	Bank Scenario #2	1	MercyMwili	60 min	21/07/2020
Bank Scenario #2 - QA	Bank Scenario #2	1	tkchoqe	60 min	21/07/2020
Vodacom Mozambique Ethical Ninja Training	Ethical Ninja Sama	11	ikua_mike	7200 min	27/07/2020

Events Calendar



- One Click to Create Multi-User Events
 - ❑ Multiple isolated networks or Shared networks
 - ❑ Automatic orchestration of attack simulation
- Numerous Applications
 - ❑ Red vs. Blue teams exercises
 - ❑ Security Training
 - ❑ Competence Assessment
 - ❑ Staff Recruitment
- Events Calendars
- Invite Users to Join Events

Reporting

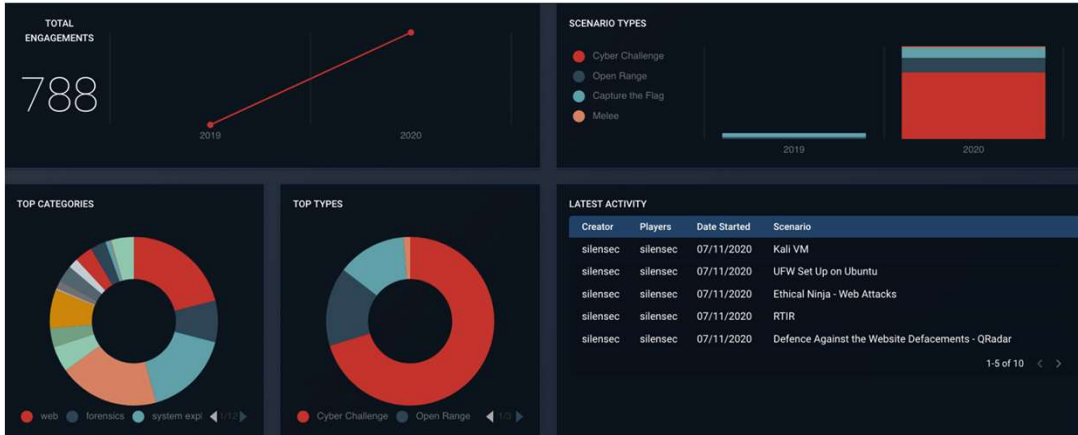

Organizational View

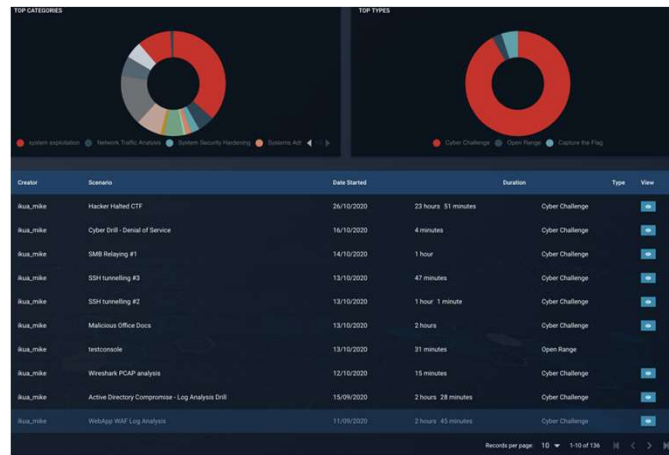

Tracking User/s Progression



- Manage Organizations
 - ❑ Manage teams and staff
 - ❑ Assign users to scenarios
- Track User/s Progression
 - ❑ Engagement
 - ❑ Competency areas
- xAPI Compliance
 - ❑ Integrate with third-party LMS

Administration and MSSP

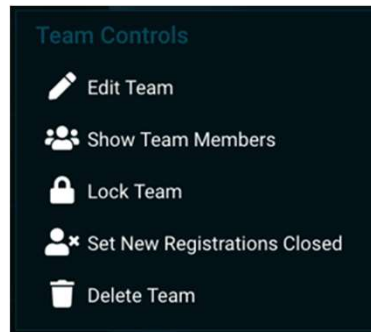
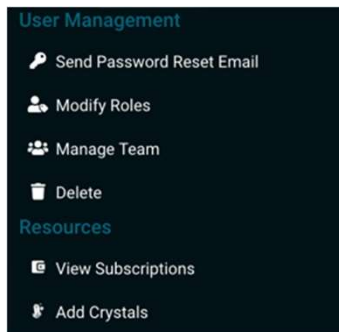
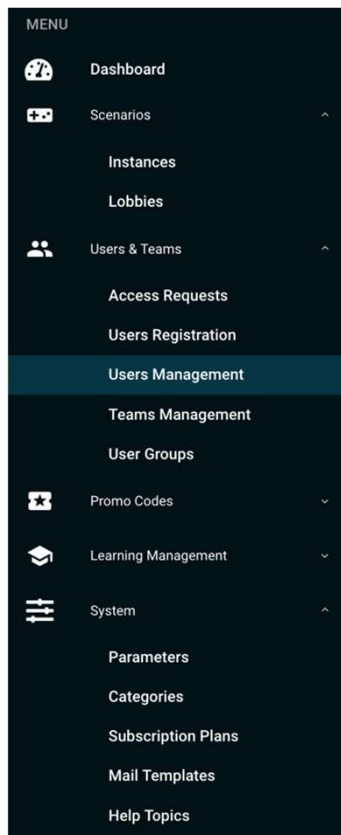

Users and Teams Management

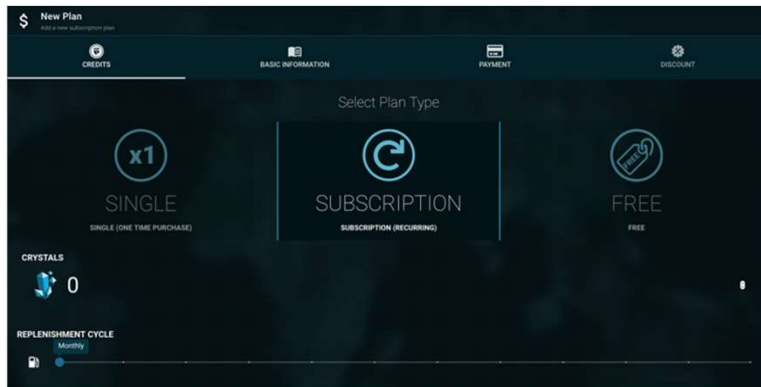

- CYBER RANGES Administration
 - ❑ Manage Scenarios and Events
 - ❑ Manage Users and Teams
 - ❑ Manage Permissions
 - ❑ Manage Competency Frameworks
- MSSP Functionalities
 - ❑ Manage Subscription Plans
 - ❑ Issue Promo Codes
 - ❑ Create and Manage Organizations

Why CYBER RANGES by Silensec

- Leading the Cyber Range Technology Innovation
- Delivered also on-premise, built to scale
- Start using CYBER RANGES for security training and continue using it for:
 - competence-based recruitment
 - development of cyber capabilities
 - profiling skills at national level
 - improving cyber resilience
 - proof of concept, product testing

... *and much more*

CYBER SPACE, ENGAGED.



CYBER RANGES

Thank you!

www.cyberranges.com

Professionals

Information Security

Cyprus | Kenya | England

